

LEVTECH

FUME CUPBOARD

LSB1.5 series

**General Purpose
Acid Perchloric**

www.levsb.com



LEVTECH

FUMECUPBOARD

Introduction

Simple everyday work in chemical laboratory such as mixing, decanting, heating, evaporating, ect., can field all kinds and type of fumes, vapours and gases which can be dangerous or even fatal to the operator. These tasks can be safely done within the confines of properly designed and constructed fumecupboard. The fume cupboard should draw the fumes, vapours and gases away from the operator offering a safe environment to work in. The operation of the fume cupboard must be efficient, functional and conducive to the user and yet do not interfere with the experiment.

Descriptions

The LEVTECH Fumecupboards are of the aerodynamic bench type complete with an automatic air-by-pass system. It is constructed in accordance with this specification by an established manufacturer experience in design and manufacturer of aerodynamic fume cupboards. The design shall give a very high degree of protection as well as facilities for sophisticated accessories.

Type

LEVTECH offers various type of fumecupboard for any application from chemistry to microbiology. EVTECH Fumecupboard are available in various type and models or individually designed to suit special requirements. Model available are :

- General Purpose
- Perchloric Acid Application
- Hydrofluoric Acid Application
- Radioisotope Application

Size

The Fumecupboard are made in three standard size of 1.2 meter, 1.5 meter and 1.8 meter. Standard depth of 760mm, Standard height of 1500mm. Standard height of under bench unit will be 900mm.

Construction

The fume cupboard will be double all construction with outer shell of E.G. steel sheet of 0.8 mm and epoxy powder coated to 80 micron and oven baked finish. The fumecupboard incorporate an air by-pass system to overcome face velocities at lower sash opening. This is to allow for constant extraction at any sash position. The fumecupboard unit generally be not less than 1.5m width x 0.75m depth x 1.5m height. The aerofoil shaped sides have a minimum 100 mm wall thickness.

Inner Chamber

The inner chamber is moulded in one piece with an unbroken gelcoat, without seams or joints. The corners are radiuses to prevent accumulation of dirt, and to facilitate decontamination. The roof of the chamber is made flat to give maximum headroom. The fume outlet is sized to the maximum width of the inner chamber to provide even suction of fumes, manufactured from fire and chemical resistant glass reinforced plastic complying to AS 1530 part 3. 1973.

Rear Baffle

The rear baffle is one of the important component in the Fumecupboard. It helps to even out the fume suction within the inner chamber and also assist in the disposal of heavy fumes. The baffle should be easily removeable for cleaning and decontamination. A Fumecupboard without a rear baffle should not be accepted.

LEVTECH

FUMECUPBOARD

Front Facia

The front facia is constructed with double wall construction that outer shell of E.G. steel sheet of 0.8 mm and epoxy powder coated to 80 micron and oven baked finish.

Air-Bypass System

The LEVTECH fumecupboard incorporates an automatic air-bypass system. The air-bypass system allows for the constant extraction of air at any sash opening. This will eliminate the problem of air turbulence lower sash opening and the creation of partial vacuum.

Work Surface

The standard work surface is moulded from Black or Grey Modified Epoxy Polyester Resin with Fibreglass Reinforce Plastic. It has an anti-spill edge all round to curb any accidental spillage. It is sealed to the inner chamber to prevent any leakage. A round (Sistem PA) polypropylene drip cup is provided for easy disposal of liquid chemicals.

Lighting

Lighting for the work area is provided by a 2 x 20 watts fluorescent light located outside the fume zone. The white light provides a neutral and conducive working environment. The light diffuser is sealed to prevent any leakage of fumes and it is flushed with the top panel of the inner chamber to prevent any air turbulence. It is easily accessible for maintenance.

*A specialised service for this work on a contractual basis is available,
For further information,ask for
"The Complete Fumecupboard Maintenance Programme"*

www.levsb.com

Sash

The sash is made from 6mm thick toughened glass. The sash is counterbalanced with weights linked by stainless steel cables running over nylon pulleys. The sash fits snugly into the sash guide within the side channels to provided for smooth and easy operation. The leading edge of the sash incorporated a full width finger grip. A gap of 50mm is provided at the bottom of the sash when it is in a fully closed position.

Services and Fittings

The services are mounted on the facia of the base cabinets. All services are of the remote control type and colour coded to DIN 12920.

Standard Services include:

- * Light switch to operate the twin fluorescent light.
- * 2 nos. 13 amp. electrical switch socket outlet
- * Remote control low pressure gas outlet
- * Remote control cold water outlet
- * Fan control switch and isolator (to be located near the fumecupboard)

Base Cabinet

The base cabinet is made from Electro Galvanised Steel sheet of 0.8 mm thick. Vertical support been fabricated from 1.0 mm steel. The cabinet approximately 900-mm (H) x 1500-mm (W) and 760-mm (D). The base cabinet have double leaf doors and one removable and adjustable shelf.

Maintenance

After use, wash down the inside surface with water and detergent or mild neutraliser of most commonly used reagent or chemical. Periodic maintenance at regular intervals is desirable to optimised the performance of the fumecupboard and prevent structural deterioration.

LEVTECH

FUMECUPBOARD

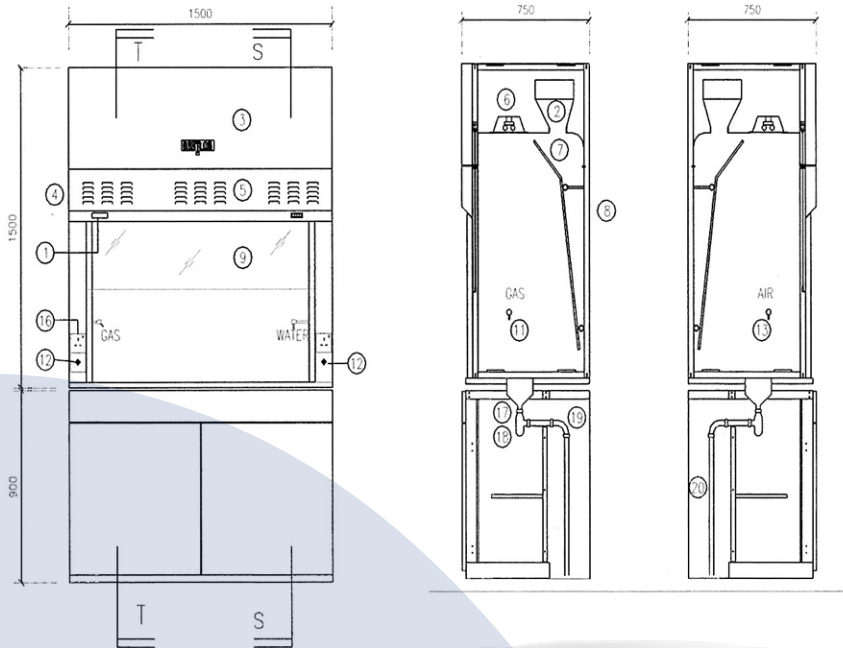

LEVTECH SDN. BHD. (760493-M)

No. 18, Lorong Idaman 2/6,
Taman Idaman,
14100 Simpang Ampat (S.P.S)
Pulau Pinang, Malaysia.
Tel / Fax : 04 - 240 8151
Email : fikri_levtech@yahoo.com.my
Mohamad Fikri B. Mohamad Ariff (H/p : 017 - 660 3151)
www.levsb.com
GST No : 000095789056

Other Product & Services Available

- Chemical Resistant Centrifugal Fan
- Wash Demist (Fume Scrubber System)
- Chemical Resistant Plumbing System
- Laboratory Furniture System
- Modified Epoxy Polyester Resin Worktop
- Phenolic Resin Worktop
- Laboratory Gas and Water Fittings
- Emergency/Eye Shower System
- Fumecupboard Repair and Maintenance Services
- Laboratory Design Consultancy
- Hygiene Industrial II Inspection
- Local Exhaust Ventilation System Inspection

www.levsb.com